



www.macis.com.sg

PILOT VALVE (Manual Reset Type)

Valve Operation

MV 29176-55H, MV 29176-55H-D & MV 29178-55H-D are 3 Way 2-Position, Normally closed, Manual palm button, Air latch pilot with spring return pilot valves, manual reset type.

To open the valve, the pressure signal to Pilot port within the required minimum pilot pressure range and manually pull the palm button to actuate, the valve will open the supply pressure from IN port to OUT port and block at the EX port, as per below Control Table (State 2). Once Pulling palm button outward and applied pilot signal pressure, the valve's normal in-service placement will be maintained. To close the valve, manually push in palm button even when there is pilot signal pressure within the min pilot pressure range, the valve will spring return to close as per below Control Table (State 1). The supply pressure will be block at IN port and the valve will vent accumulated operating pressure from OUT port to EX port. Reintroduction of the pilot signal pressure will not open the valve unless the palm button is manually pulled.

* Note: When pilot port Loss of the pressure supply or pressure signal drop to lower than 20psi (1.4bar), the valve will spring return to close see Control Table (state 1).

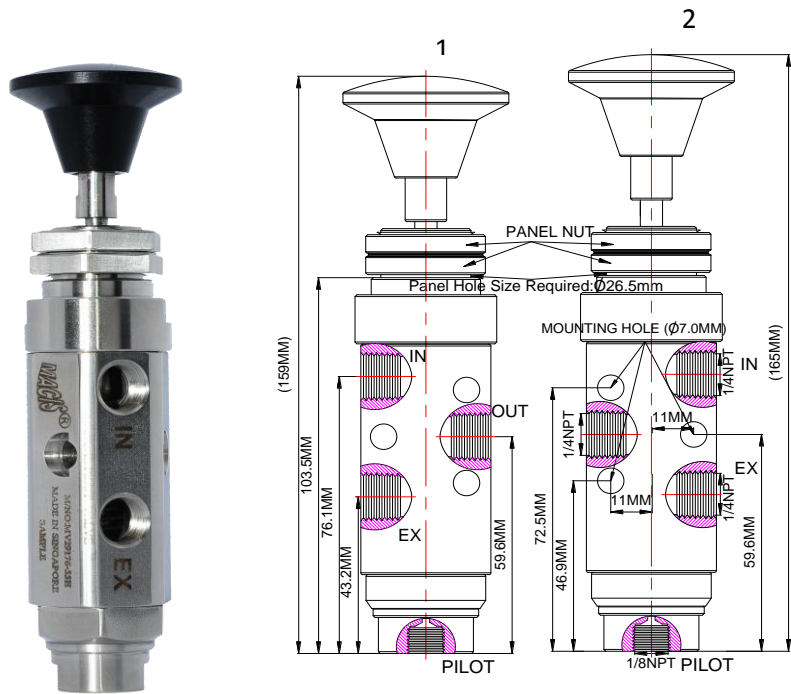

Ordering Ref : MV 29176-55H

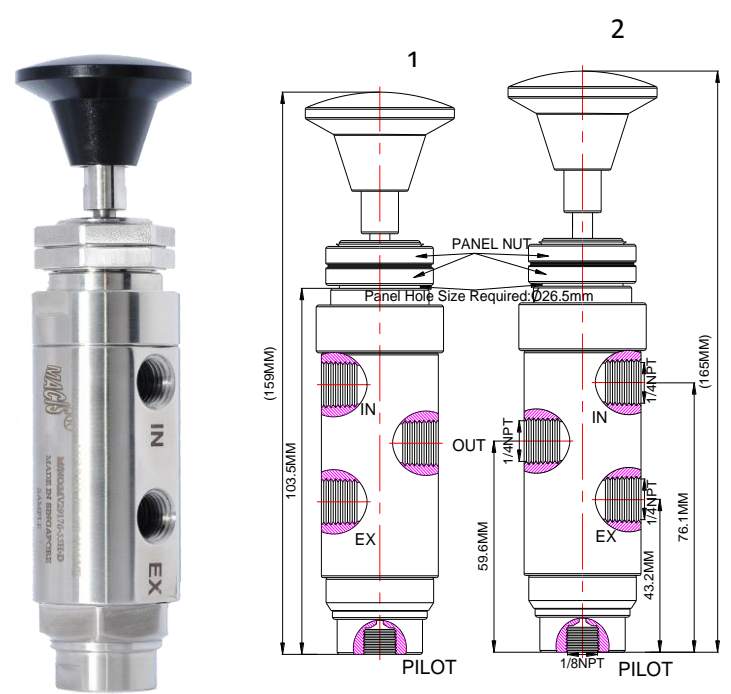

Ordering Ref : MV 29176-55H-D

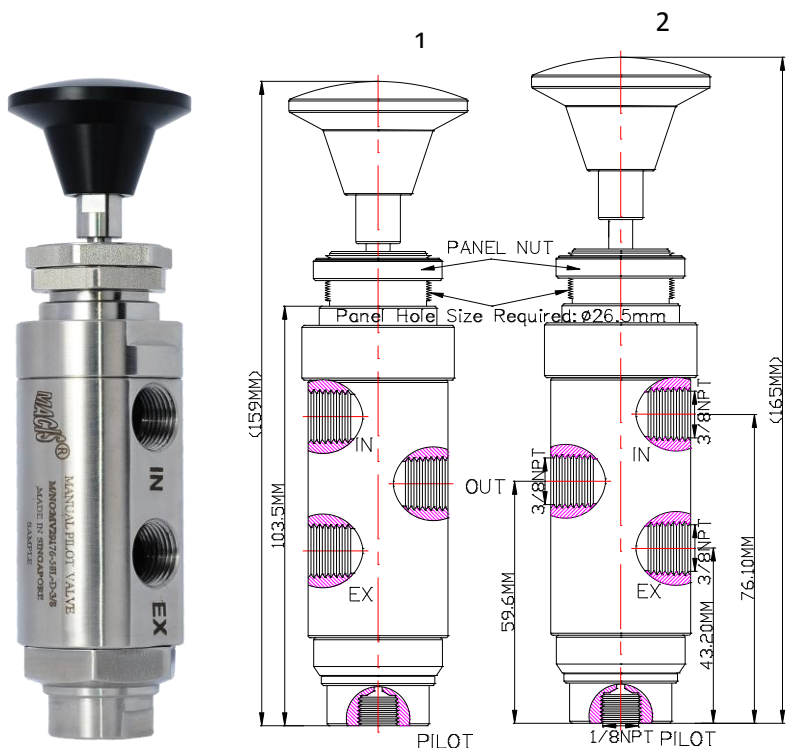

Ordering Ref : MV 29178-55H-D

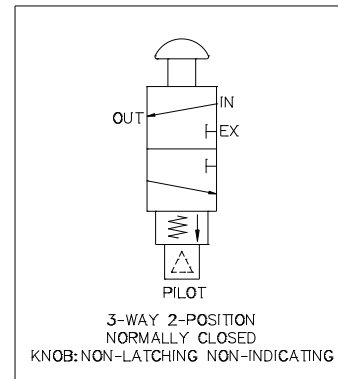

Flow Control Table (Palm Button)

STATE	IN	OUT	EX	PILOT	Palm Button
1	-	O	O	-	push
2	O	O	-	O	pull

Specification

Control Application	3-Way 2-Position, Normally Closed Manual Palm Button, Air Latch Pilot With Spring Return, Manual Reset Type	Distinctions	
Working Media	Oil	Ordering Ref no	Port Connection Size
Pilot Pressure Range	30 - 200 PSI (2.1 – 13.7bar)	MV 29176-55H:	Hexagon A/ F 34.9mm (1 3/8")
Max Working Pressure	200psi (13.7bar)	} IN , OUT & EX Ports : 1/4"NPT F Pilot Port : 1/8"NPT F	Ø7.0mm(9/32")
Temperature Range	- 30°C to 120°C <i>Other Temperature Ranges available. Consult Factory</i>		MV 29176-55H-D :
Material(Valve Body)	316 L		Without
Panel Hole Size	Ø 26.5mm (1 3/64")	MV 29178-55H-D:	IN , OUT & EX Ports : 3/8"NPT F
Net Weight	850gm		Pilot Port : 1/8"NPT F
Material(Palm Button)	Polyamide <i>Other Material Available Upon Request</i>		Circular Ø 40.0mm (1 37/64")
Flow Rate	Cv = 1.65		Without

** Measurement stated are with tolerance of +/-10%. Optional Parts/Material are available upon request.

MACIS PTE LTD

Blk 3015A Ubi Road 1, #01-02 & #01-06 Kampong Ubi Industrial Estate, Singapore 408705
Email : sales@macis.com.sg TEL : 65-6749 6011 / 65- 6749 7882 FAX : 65-6749 1398