



www.macis.com.sg

NEEDLE VALVE (Straight Pattern)

Descriptions

The needle valve is used to make relatively fine adjustments in the amount of fluid flow. They are often used as component parts of other valves, to shut off the flow of the process media to the pressure instrument.

The characteristic of this valve is the long, tapered, needle like point on the end of the valve stem. This "needle" acts as a disk. The longer part of the needle is smaller than the orifice in the valve seat and passes through the orifice before the needle seats. This arrangement permits a very gradual increase or decrease in the size of the opening in a needle valve. Therefore, the valve can to provide fine flow adjustments. The number of handle turns can be directly correlated to the amount of flow.

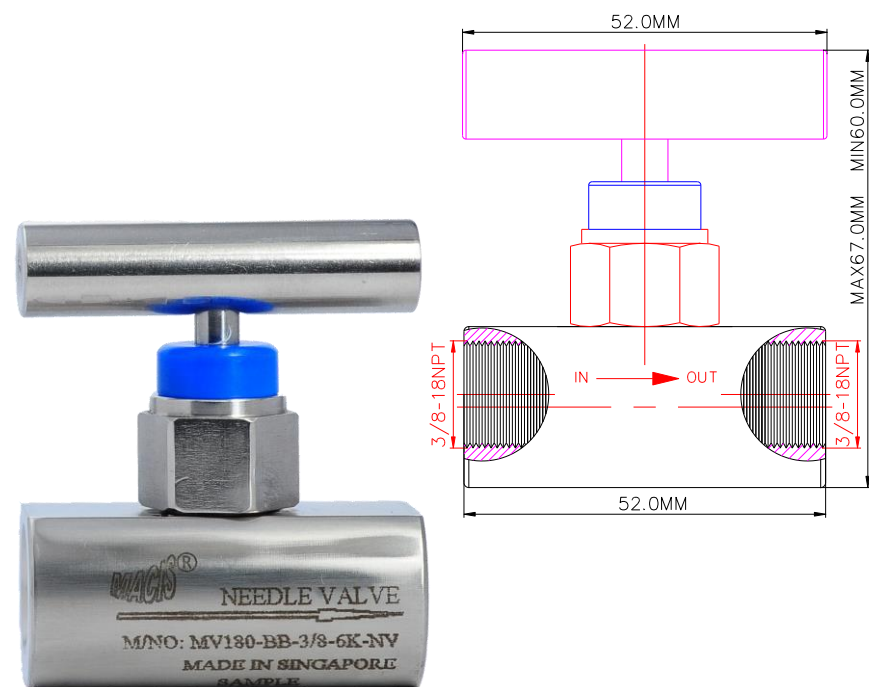
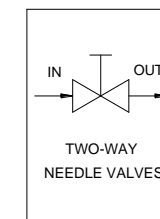

Ordering Ref : MV 180-BB-3/8-6K-NV-L

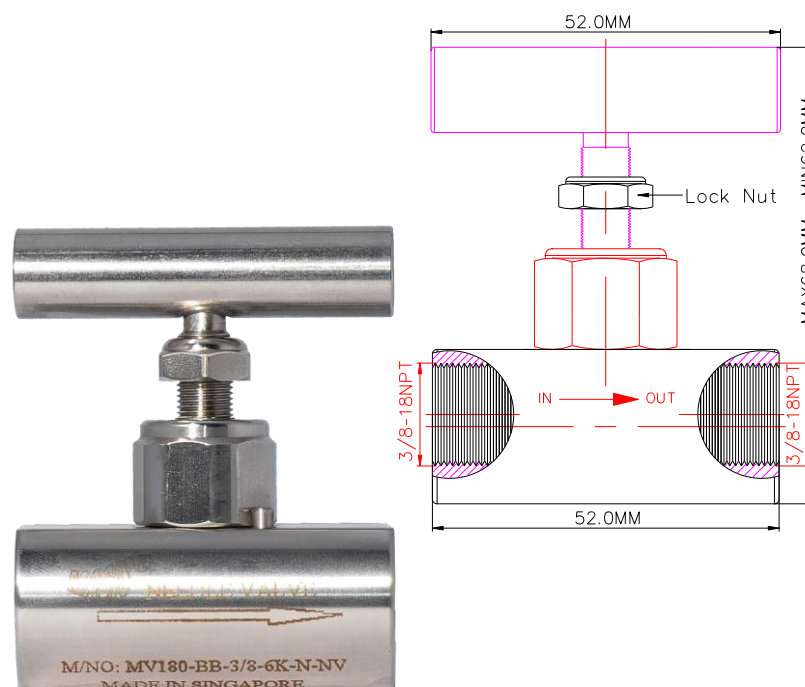

Ordering Ref : MV 180-BB-3/8-6K-N-NV-L

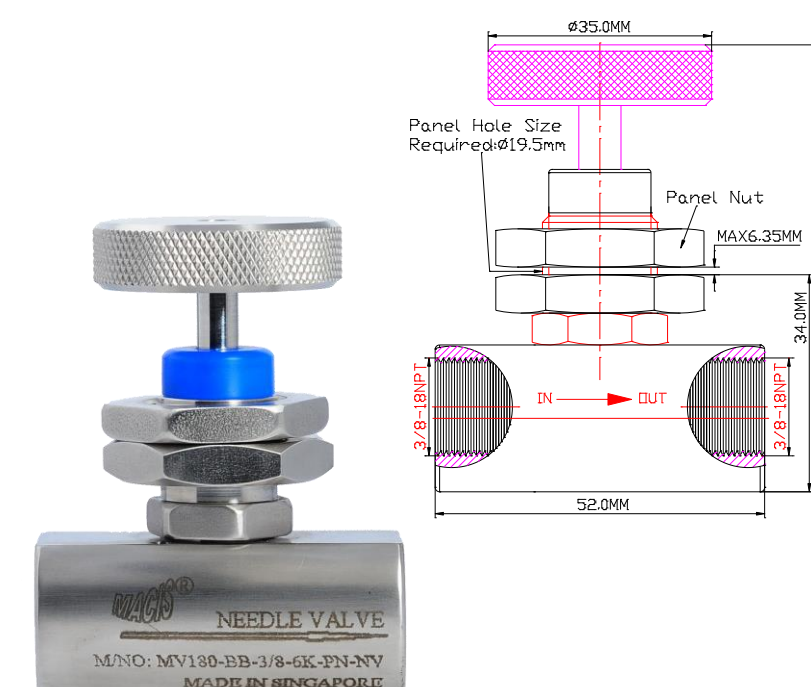

Ordering Ref : MV 180-BB-3/8-6K-PN-NV-L

Specification

Port Connection Size	IN Port: 3/8"-18NPT F OUT Port: 3/8"-18NPT F	Distinctions <table border="1"> <thead> <tr> <th>Ordering Ref No</th> <th>Net Weight</th> <th>Stem Seal</th> <th>Locknut</th> <th>Panel Hole</th> </tr> </thead> <tbody> <tr> <td>MV 180-BB-3/8-6K-NV-L :</td> <td>280gm</td> <td>With</td> <td>Without</td> <td>Without</td> </tr> <tr> <td>MV 180-BB-3/8-6K-N-NV-L :</td> <td>280gm</td> <td>Without</td> <td>With</td> <td>Without</td> </tr> <tr> <td>MV 180-BB-3/8-6K-PN-NV-L :</td> <td>340gm</td> <td>With</td> <td>Without</td> <td>Ø 19.5mm(49/64")</td> </tr> </tbody> </table>	Ordering Ref No	Net Weight	Stem Seal	Locknut	Panel Hole	MV 180-BB-3/8-6K-NV-L :	280gm	With	Without	Without	MV 180-BB-3/8-6K-N-NV-L :	280gm	Without	With	Without	MV 180-BB-3/8-6K-PN-NV-L :	340gm	With	Without	Ø 19.5mm(49/64")
Ordering Ref No	Net Weight		Stem Seal	Locknut	Panel Hole																	
MV 180-BB-3/8-6K-NV-L :	280gm		With	Without	Without																	
MV 180-BB-3/8-6K-N-NV-L :	280gm		Without	With	Without																	
MV 180-BB-3/8-6K-PN-NV-L :	340gm		With	Without	Ø 19.5mm(49/64")																	
Working Media	Air																					
Max Working Pressure	6,000psi (413.7 bar)																					
Temperature Range	- 30°C to 120°C <i>Other Temperature Ranges available. Consult Factory</i>																					
Material(Valve Body)	316L																					
Exterior Shape	Circular Ø31.0mm (1 ⁷ / ₃₂ ")																					
Orifice Size	Ø4.2mm (1 ¹ / ₆₄ ")																					
Seal Material	Viton(FKM) <i>Other Seal Material are Available Upon Request</i>																					
Flow Rate	Cv = 0.7																					
Options	Body Material and end connections other option available upon request																					

** Measurement stated are with tolerance of +/-10%. Optional Parts/Material are available upon request.

MACIS PTE LTD

Blk 3015A Ubi Road 1, #01-02 & #01-06 Kampong Ubi Industrial Estate, Singapore 408705
Email : sales@macis.com.sg TEL : 65-6749 6011 / 65-6749 7882 FAX : 65-6749 1398