



www.macis.com.sg

## VELOCITY CHECK VALVE

### Valve Operation

MV1586779L-A is a Velocity Manual Check Valve, it is to provide positive flow shut off in the event of an abnormal flow thru pressure differential. To open the valve, manually push the palm button until the pressure equalizes on both sides and allow the spool to stay at the in position, as status table on state 2.

Releasing the palm button, the valve will still stay at in position unless the palm button is manually pull to allow the valve and ball check to it position, the pressure flow from OUT port to IN port, pressure loss in the downstream of the OUT port will causes the valve to trip as status table on state 1.

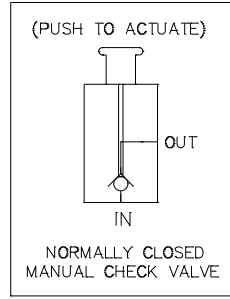

Flow Control status Table

STATE	IN	OUT	Palm Button
1	-	O	pull
2	O	O	PUSH

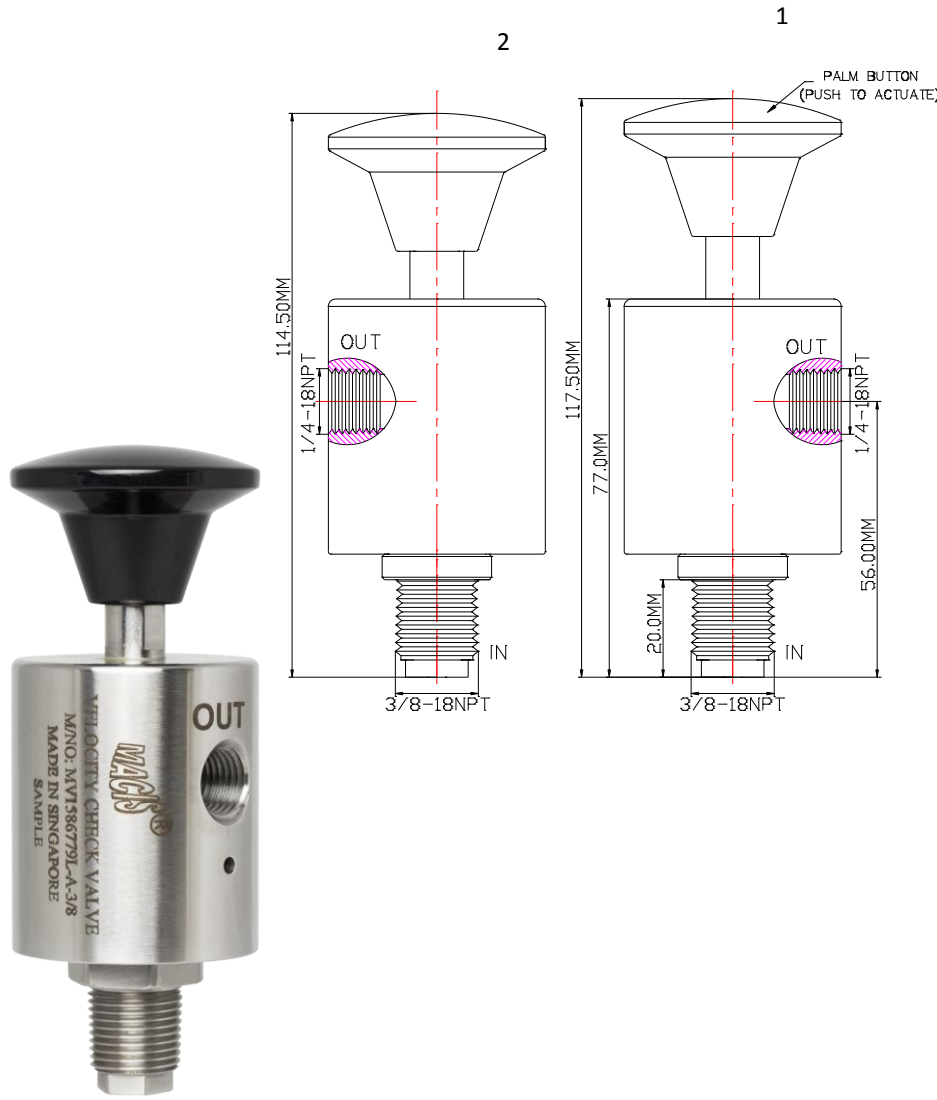

Ordering Ref : MV1586779L-A-3/8

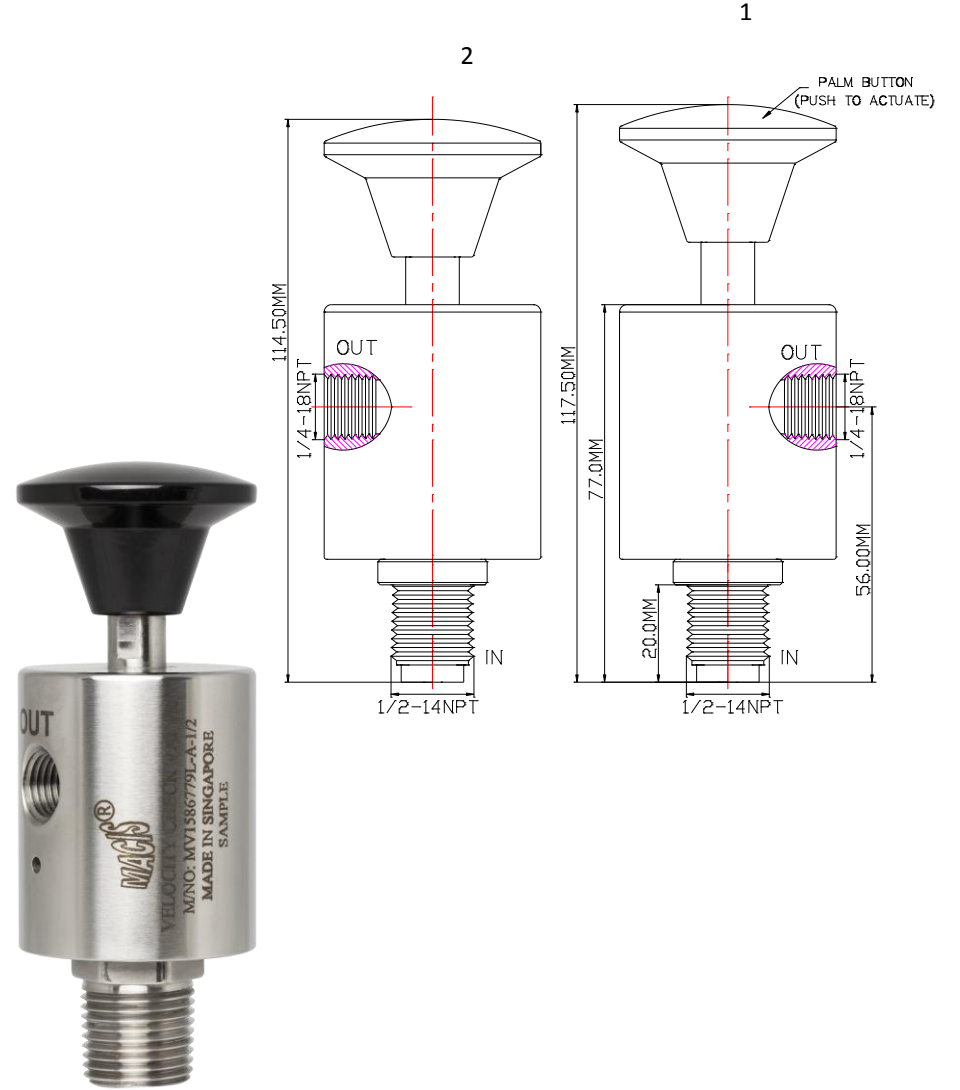

Ordering Ref : MV1586779L-A-1/2

### Specification

Control Application	2-Way Normally Closed Velocity Check Valve with Manual Palm Button Type
Exterior Shape	Circular Ø44.00 mm (1 7/64")
Net Weight	1.0 Kg
Working Media	Air
Max Working Pressure	10,000 PSI (689.4bar)
Operating Pressure (Palm Button)	0-2,000PSI( 0-137.9bar)
Temperature Range	- 30°C to 120°C <i>Other Temperature Ranges available. Consult Factory</i>
Material(Valve Body)	316 L
Seal Material	Viton(FKM) <i>Other Seal Material are Available Upon Request</i>
Material (Palm Button)	Polyamide <i>Other Material are Available Upon Request</i>
Flow Rate	Cv = 0.35

### Distinctions

Ordering Ref No : MV 1586779L-A-3/8



Port Connection Size : IN Port : 3/8" NPT M , OUT Port : 1/4" NPT F

Ordering Ref No : MV 1586779L-A-1/2



Port Connection Size : IN Port : 1/2" NPT M , OUT Port : 1/4" NPT F

\*\* Measurement stated are with tolerance of +/-10%. Optional Parts/Material are available upon request.

MACIS PTE LTD

Blk 3015A Ubi Road 1, #01-02 & #01-06 Kampong Ubi Industrial Estate, Singapore 408705  
Email : [sales@macis.com.sg](mailto:sales@macis.com.sg) TEL : 65-6749 6011 / 65-6749 7882 FAX : 65-6749 1398