



www.macis.com.sg

## VELOCITY CHECK VALVE

### Valve Operation

Velocity Manual Check Valve (MV1586778H) is to provide positive flow shut off in the event of an abnormal flow thru pressure differential. To open the valve, push down the manual lever until the pressure equalizes on both sides (Input & Output) and allow the spool to stay at the in position, as status table on state 2.

Release the manual lever, the spring return valve and the ball check to its position, the pressure flow from OUT port to IN port. Pressure loss in the downstream of the OUT port will cause the valve to trip as status table on state 1.

This type valve also being used with independent operation system, such as LPO (Line Pressure Operate) systems. They provide both the pressure shut off response and the manual reset feature required by LPO systems.

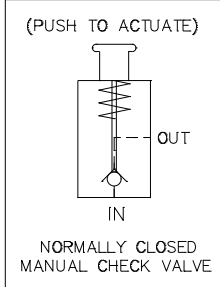

Flow Control Status Table

STATE	IN	OUT	MANUAL LEVER
1	-	O	Release
2	O	O	Push Down



Ordering Ref : MV1586778H-3/8

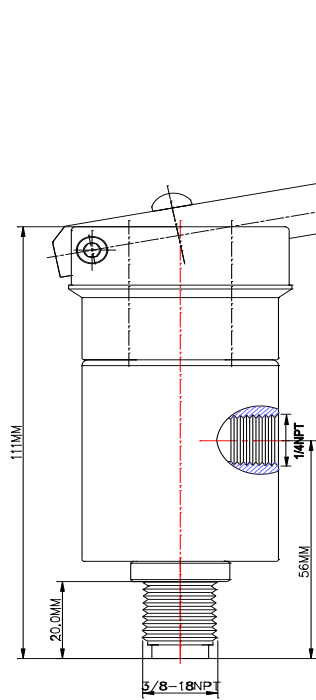

Ordering Ref : MV1586778H-1/2

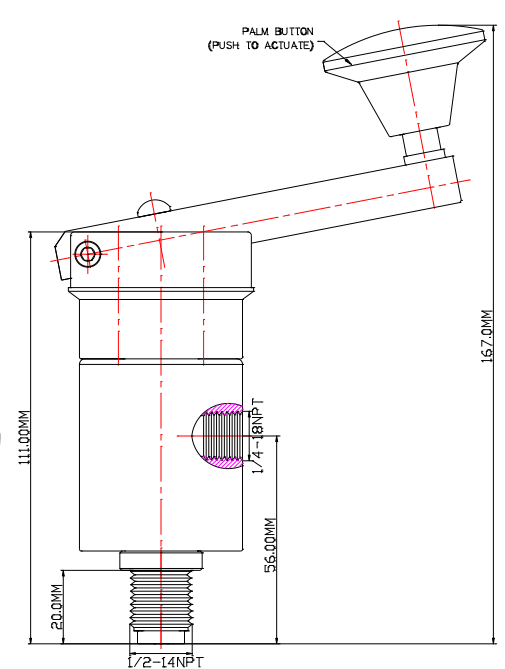

### Specification

Control Application	2-Way Normally Closed Velocity Check Valve with Manual Lever Type
Exterior Shape	Circular Ø44.00 mm (1 47/64")
Net Weight	1.2 kg
Working Media	Oil
Max Working Pressure	10,000 PSI (689.4bar)
Operating Pressure (Manual Lever)	0-10,000PSI( 0-689.4bar)
Temperature Range	- 30°C to 120°C <i>Other Temperature Ranges available. Consult Factory</i>
Material(Valve Body)	316 L
Seal Material	Nitrile Rubber(NBR) <i>Other Seal Material are Available Upon Request</i>
Material (Palm Button)	Polyamide <i>Other Material are Available Upon Request</i>
Flow Rate	Cv = 0.35

### Distinctions

Ordering Ref No : MV 1586778H-3/8



Port Connection Size: IN Port : 3/8" NPT M , OUT Port : 1/4" NPT F

Ordering Ref No : MV 1586778H-1/2



Port Connection Size : IN Port : 1/2" NPT M , OUT Port : 1/4" NPT F

\*\* Measurement stated are with tolerance of +/-10%. Optional Parts/Material are available upon request.

MACIS PTE LTD

Blk 3015A Ubi Road 1, #01-02 & #01-06 Kampong Ubi Industrial Estate, Singapore 408705  
Email : [sales@macis.com.sg](mailto:sales@macis.com.sg) TEL : 65-6749 6011 / 65-6749 7882 FAX : 65-6749 1398