



www.macis.com.sg

NEEDLE VALVE (Straight Pattern)

Descriptions

The needle valve is used to make relatively fine adjustments in the amount of fluid flow. They are often used as component parts of other valves, to shut off the flow of the process media to the pressure instrument.

The characteristic of this valve is the long, tapered, needle like point on the end of the valve stem. This "needle" acts as a disk. The longer part of the needle is smaller than the orifice in the valve seat and passes through the orifice before the needle seats. This arrangement permits a very gradual increase or decrease in the size of the opening in a needle valve. Therefore, the valve can provide fine flow adjustments. The number of handle turns can be directly correlated to the amount of flow.

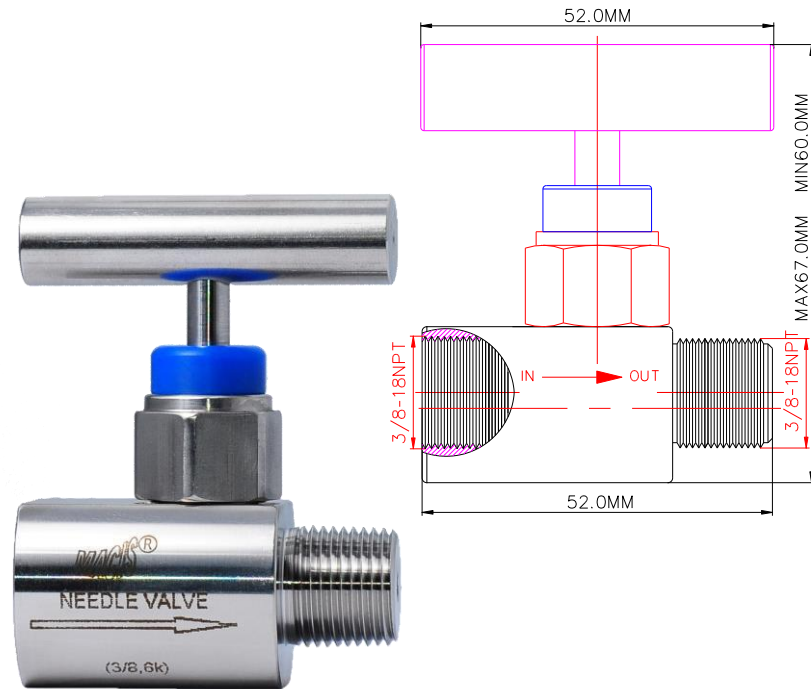
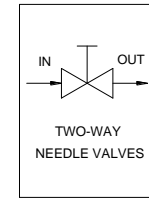

Ordering Ref : MV 180-BA-3/8-6K-NV-L

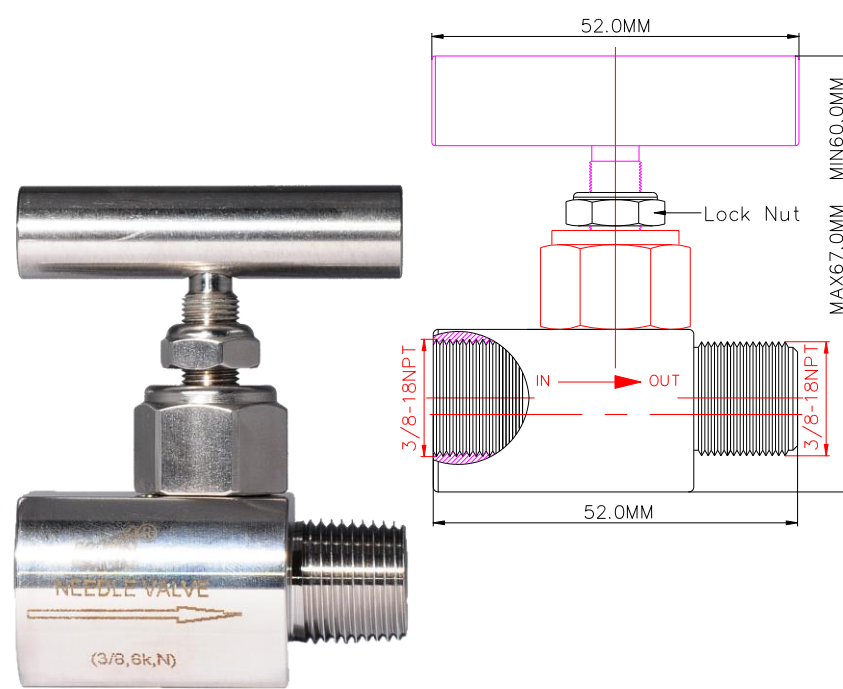

Ordering Ref : MV 180-BA-3/8-6K-N-NV-L

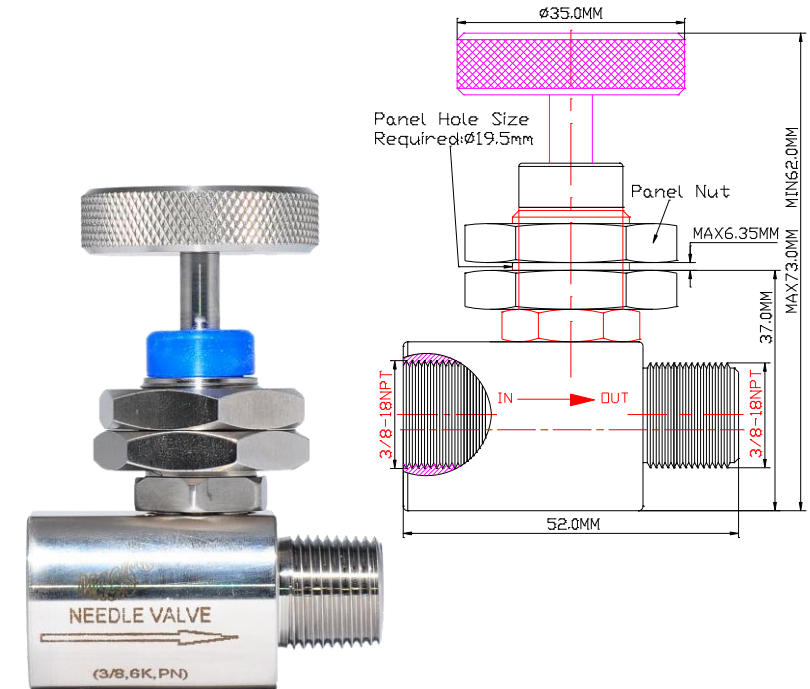

Ordering Ref : MV 180-BA-3/8-6K-PN-NV-L

Specification

| | |
|----------------------|---|
| Port Connection Size | IN Port: 3/8"-18NPT F OUT Port: 3/8"-18NPT M |
| Working Media | Air |
| Max Working Pressure | 6,000psi (413.7 bar) |
| Temperature Range | - 30°C to 120°C <i>Other Temperature Ranges available. Consult Factory</i> |
| Material(Valve Body) | 316L |
| Exterior Shape | Circular Ø31.0mm (1 7/32 ") |
| Orifice Size | Ø4.2mm (11/64") |
| Seal Material | Viton(FKM) <i>Other Seal Material are Available Upon Request</i> |
| Flow Rate | Cv = 0.7 |
| Options | Body Material and end connections other option available upon request |

Distinctions

| Ordering Ref No | Net Weight | Stem Seal | Locknut | Panel Hole |
|----------------------------|------------|-----------|---------|------------------|
| MV 180-BA-3/8-6K-NV-L : | 280gm | With | Without | Without |
| MV 180-BA-3/8-6K-N-NV-L : | 280gm | Without | With | Without |
| MV 180-BA-3/8-6K-PN-NV-L : | 340gm | With | Without | Ø 19.5mm(49/64") |

** Measurement stated are with tolerance of +/-10%. Optional Parts/Material are available upon request.

MACIS PTE LTD

Blk 3015A Ubi Road 1, #01-02 & #01-06 Kampong Ubi Industrial Estate, Singapore 408705
Email : sales@macis.com.sg TEL : 65-6749 6011 / 65-6749 7882 FAX : 65-6749 1398