



www.macis.com.sg

# FLOW CONTROL VALVE

## Descriptions

Flow control valve combines a check and needle valve to provide effective speed control and fast close function. Flow adjustment can be made under pressure. When turning the manual handle clockwise and with the working pressure entering the IN port, a tapered needle acts as a fixed orifice, the effective size of this orifice is increased as tapered needle is opened controlling flow to out port. In the opposite direction, when reverse pressure flow exceeds the spring force, the spring biased ball inside the spring is unseated allowing free flow through it.

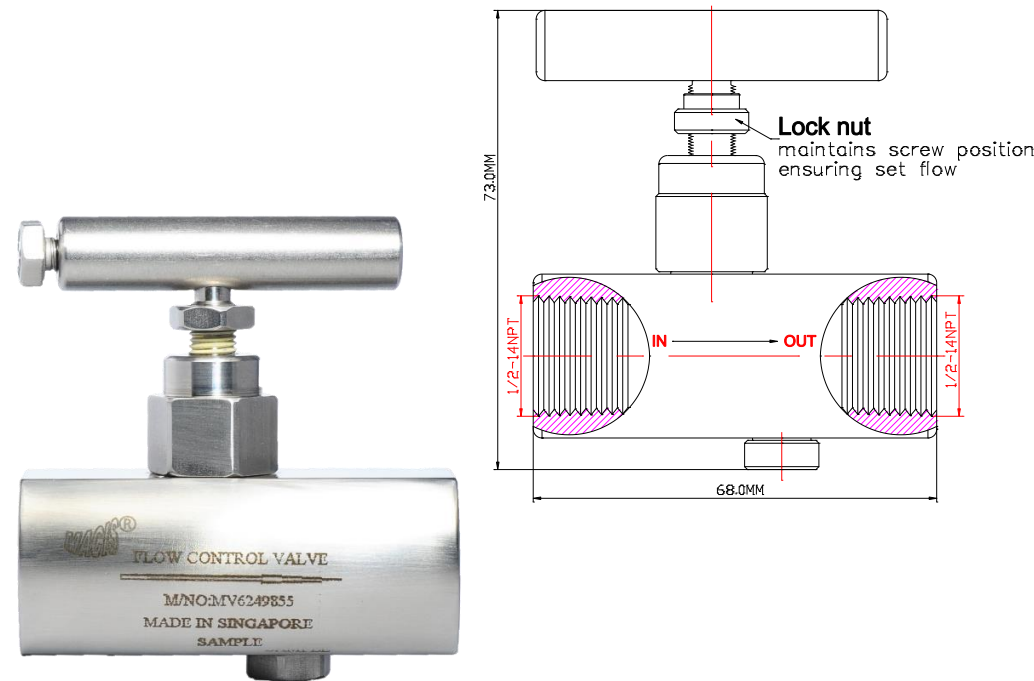
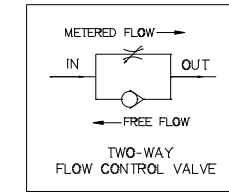

Ordering Ref : MV 6249855-6K-H

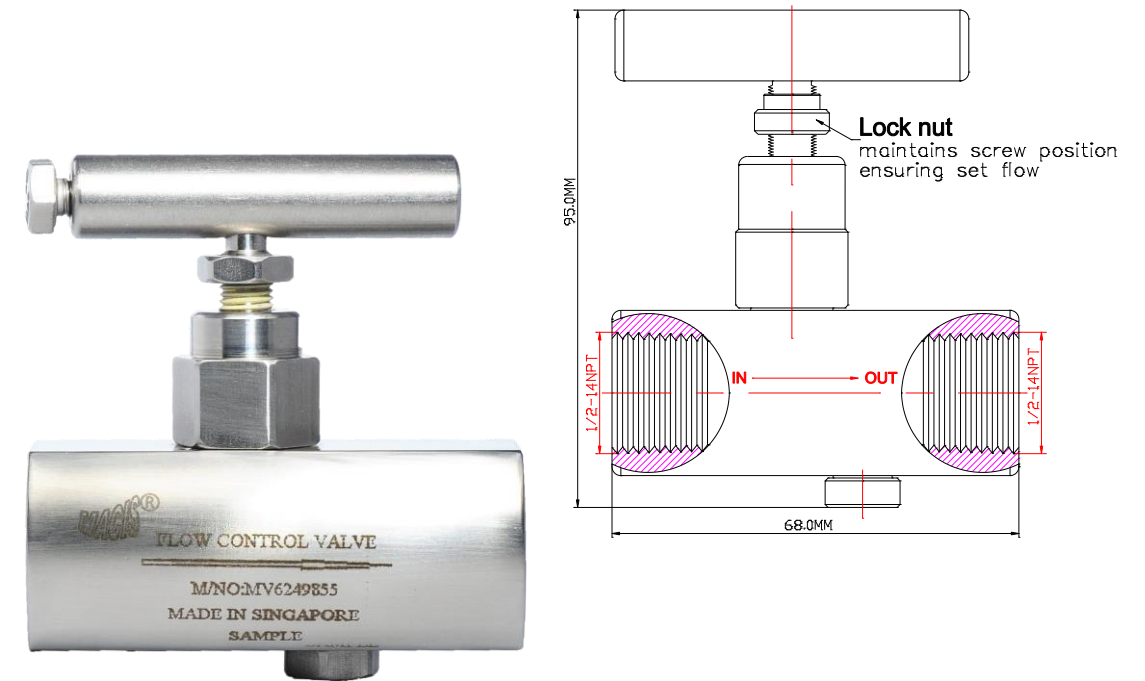

Ordering Ref : MV 6249855-10K-H

## Specification

Control Application	2-Way, Needle and the Spring Biased Ball operated , Provides controlled flow in one direction(as arrow) and allows full flow in the opposite
Port Connection Size	<b>Input:</b> 1/2"-14NPT F <b>Output:</b> 1/2"-14NPT F
Working Media	Oil
Temperature Range	- 30°C to 120°C <i>Other Temperature Ranges available. Consult Factory</i>
Material(Valve Body)	316L
Exterior Shape	Circular Ø34.5mm (1 3/8" )
Seal Material	Nitrile Rubber(NBR) <i>Other Seal Material are Available Upon Request</i>
Orifice Size	Ø 4.3 mm ( 11/64 " )
Flow Rate	Cv = 0.73
Options	Body Material and end connections other option available upon request

## Distinctions

Ordering Ref No: MV 6249855-6K-H  
 ↓  
**Max Working Pressure: 6,000psi (413.7bar)**  
**Net Weight : 510gm**

Ordering Ref No : MV 6249855-10K-H  
 ↓  
**Max Working Pressure : 10,000psi (689.4bar)**  
**Net Weight : 530gm**

\*\* Measurement stated are with tolerance of +/-10%. Optional Parts/Material are available upon request.

MACIS PTE LTD

Blk 3015A Ubi Road 1, #01-02 & #01-06 Kampong Ubi Industrial Estate, Singapore 408705  
 Email : [sales@macis.com.sg](mailto:sales@macis.com.sg) Tel : 65-6749 6011 / 65-6749 7882 Fax : 65-6749 1398