



www.macis.com.sg

(MULTI-PORT) GAUGE VALVE

Descriptions

Multi-port gauge valves are designed to be used with gauge mounting and other instrument tie-ins in the process industries, without requiring additional penetrations of the main piping. Valve with male inlet connection is available threaded or prepared for welding and with either standard or extended inlets.

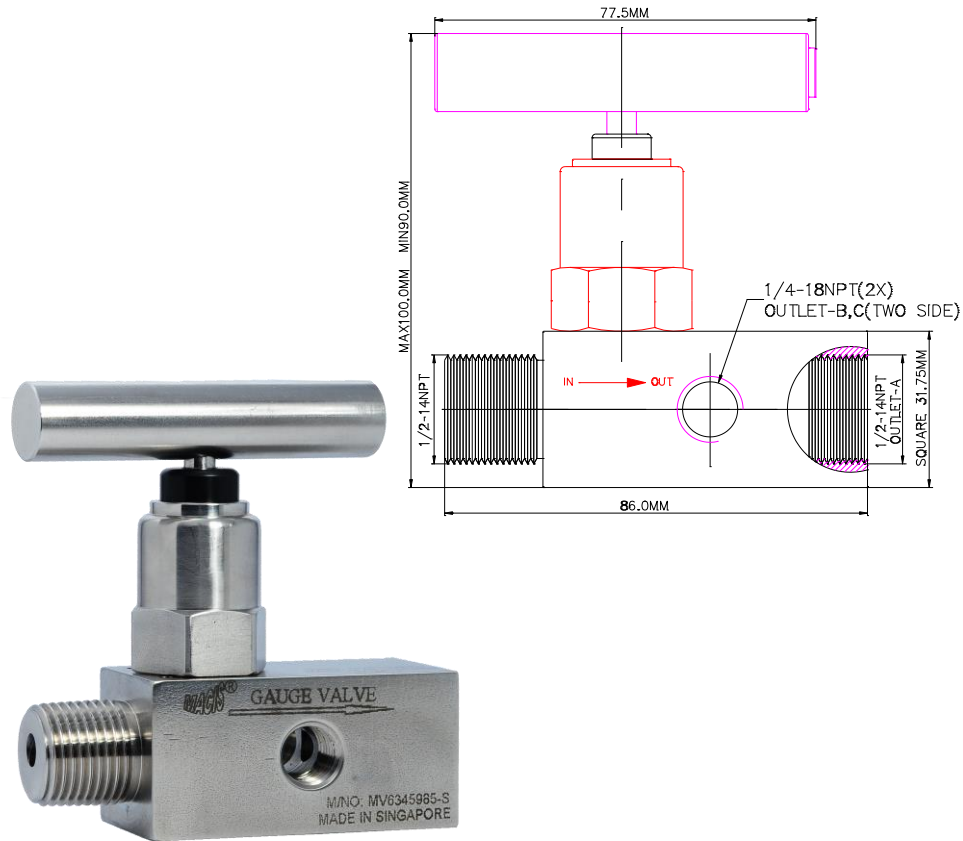

Ordering Ref : MV 6345985-S-L

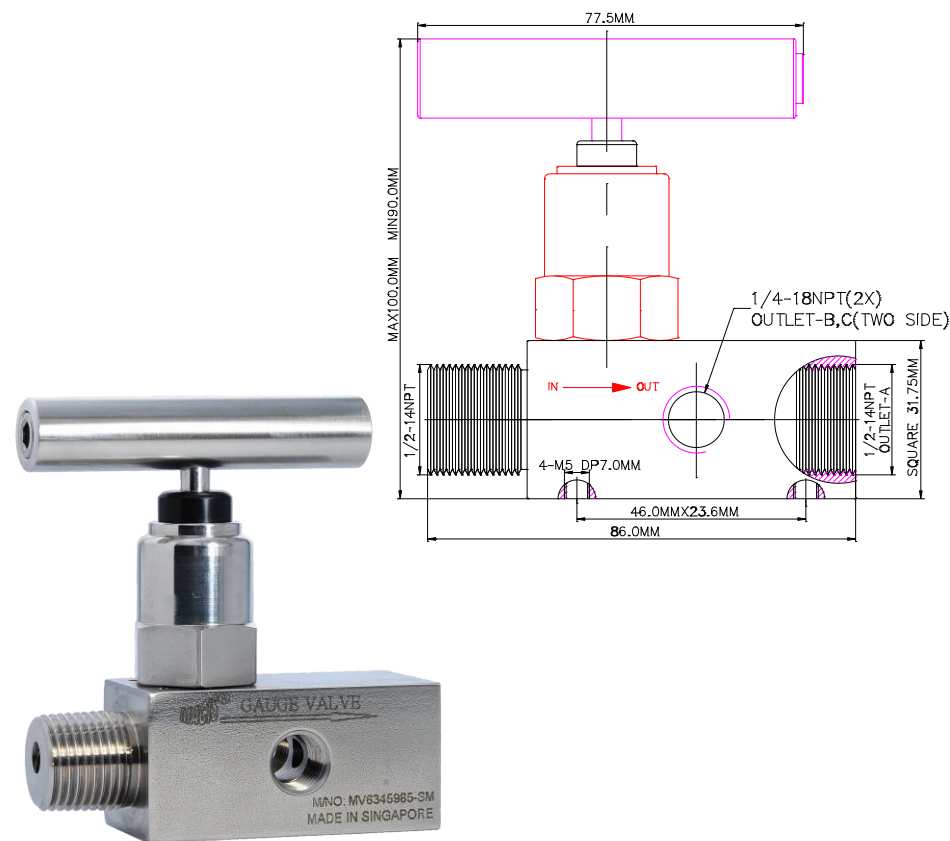

Ordering Ref : MV 6345985-SM-L

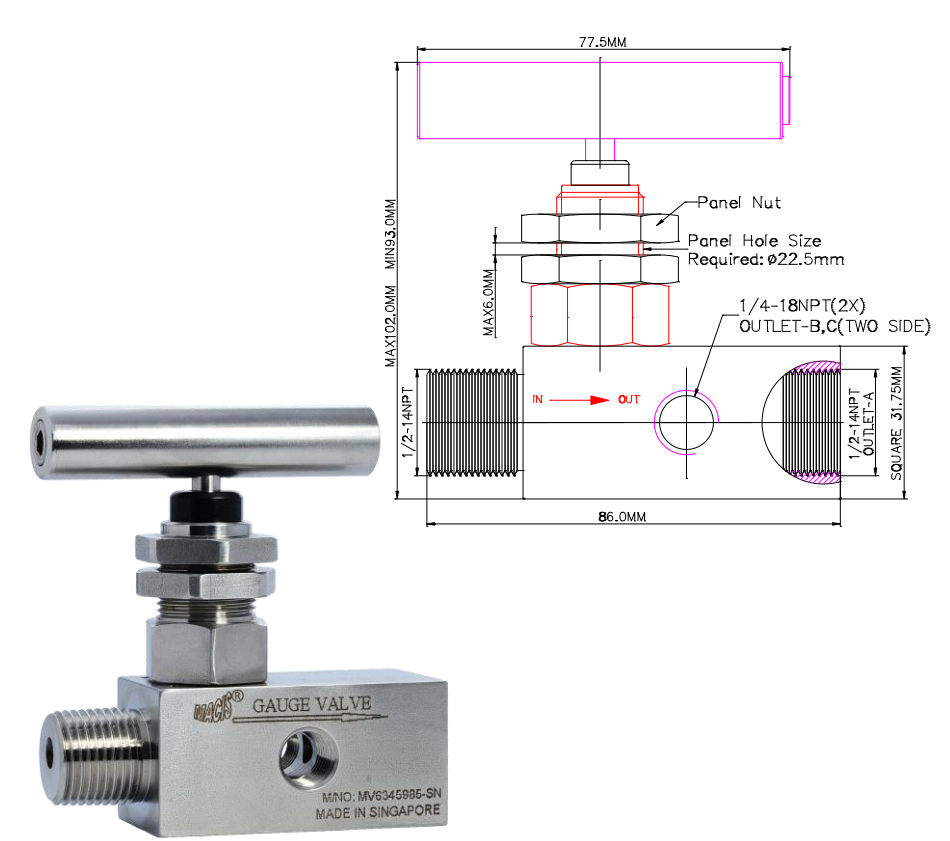

Ordering Ref : MV 6345985-SN-L

Specification

Control Application	universal use wherever more than one outlet is require
Port Connection Size	IN Port:1/2"-14NPT M OUT Port- A :1/2"-14NPT F, OUT Ports- B&C :1/4"-18NPT F
Working Media	Air
Max Working Pressure	10,000psi(689.4bar)
Temperature Range	- 30°C to 120°C <i>Other Temperature Ranges available. Consult Factory</i>
Material(Valve Body)	316 L
Exterior Shape	SQ 31.75mm × 31.75mm(1 1/4" × 1 1/4")
Orifice Size	Ø6.0mm(15/64")
Flow Rate	Cv = 1.3
Net Weight	700gm
Seal Material	Viton(FKM) <i>Other Seal Material Are Available Upon Request</i>
Options	Body Material and end connections other option available upon request

Distinctions

Ordering Ref No	Mounting Screw Hole	Panel Hole
MV 6345985-S-L :	Without	Without
MV 6345985-SM-L :	M5×DP7.0mm (9/32") (4×)	Without
MV 6345985-SN-L :	Without	Ø 22.5mm (57/64")

**Measurement stated are with tolerance of +/-10%. Optional Parts/Material are available upon request.

MACIS PTE LTD

Blk 3015A Ubi Road 1, #01-02 & #01-06 Kampong Ubi Industrial Estate, Singapore 408705
Email : sales@macis.com.sg TEL : 65-6749 6011 / 65-6749 7882 FAX : 65-6749 1398