



www.macis.com.sg

PRESSURE REGULATING VALVE

Descriptions

MV794LP10K-6K-1/4R-S / (LS / P) & MV794LF10K-6K-1/4R-P are 2-Position, Normally Open Self-Relieving Pressure regulators. A pressure regulator is a valve that automatically cuts off the flow of a gas at a certain pressure. They are used to allow high-pressure fluid supply lines to be reduced to safe and/or usable pressures for various applications.

The pressure media enters the regulator through by IN port, turning the adjusting wheel clockwise will increase the spring exerted tension to increase the regulator output pressure, rotating the adjusting wheel counterclockwise will decrease the regulator output pressure, and this reduced output pressure will be maintained within a predetermined operating pressure range or limit.

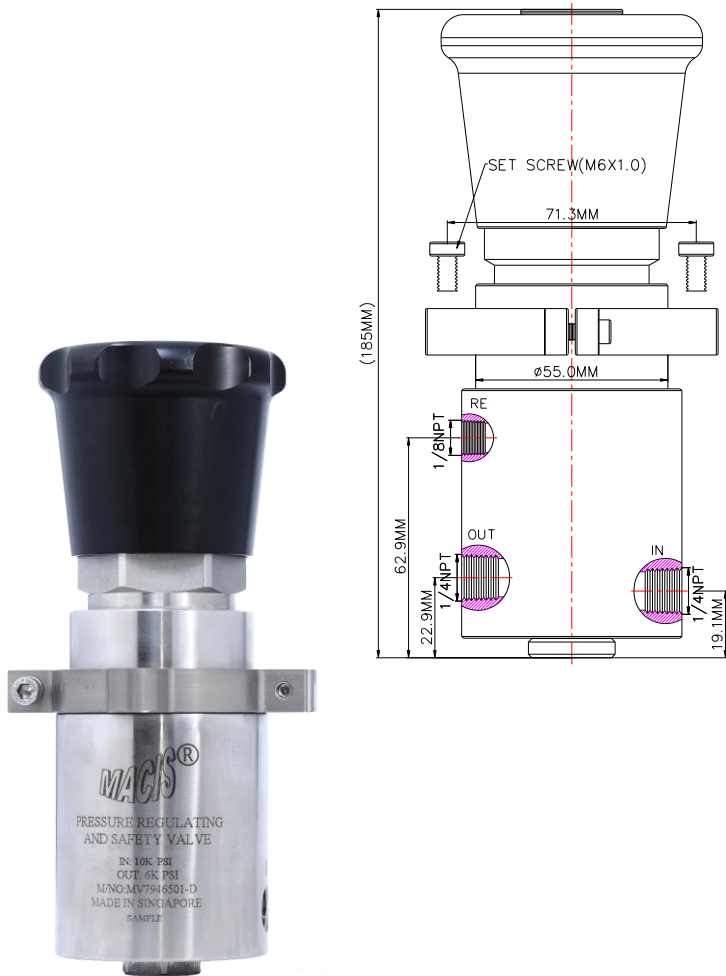
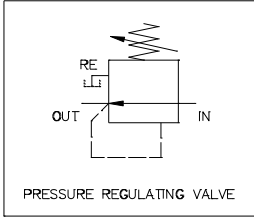

Ordering Ref : MV 794LP10K-6K-1/4R-S
Corresponding Ordering Ref : MV 7946501-D-L

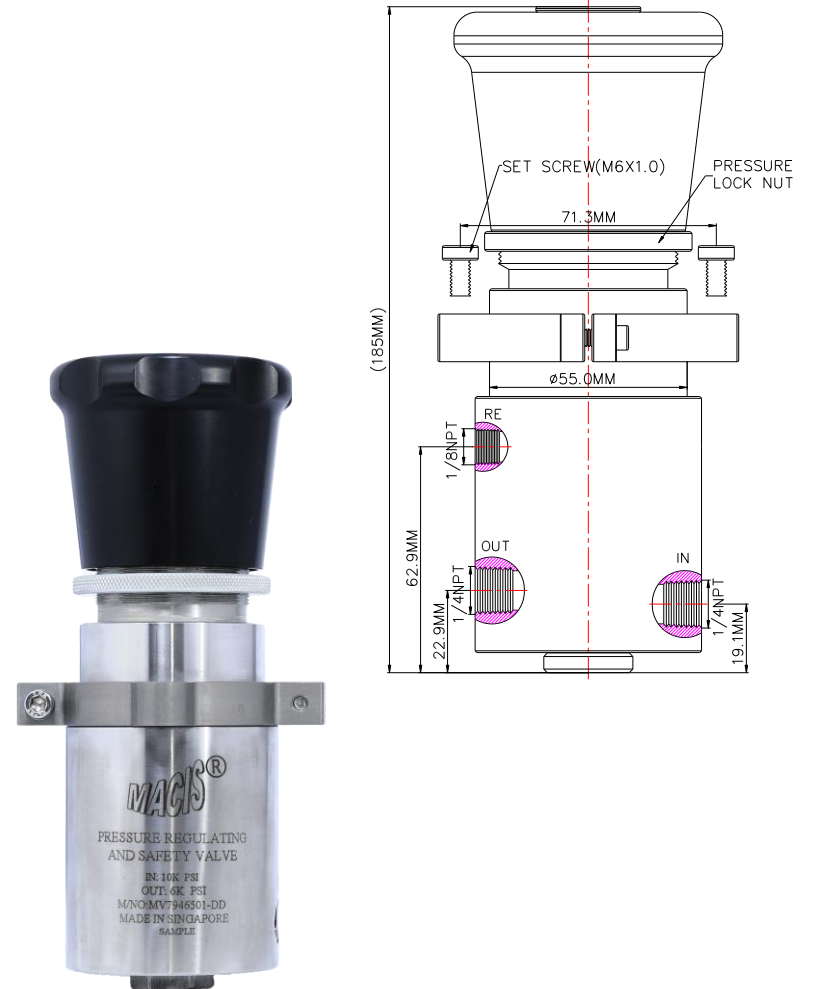

Ordering Ref : MV 794LP10K-6K-1/4R-LS
Corresponding Ordering Ref : MV 7946501-DD-L

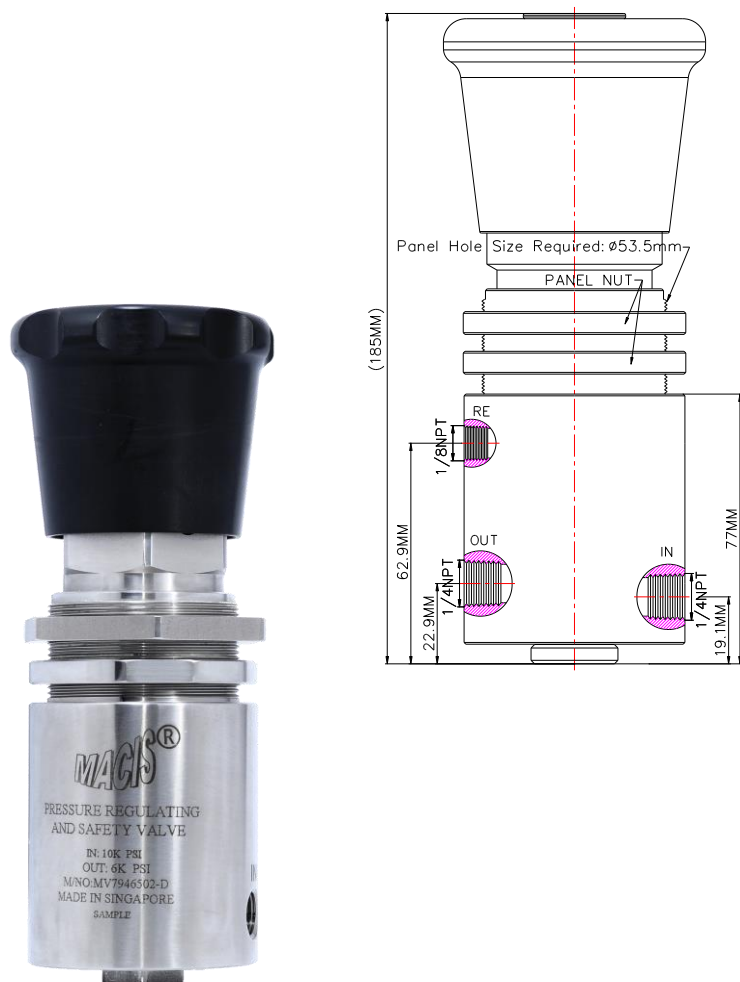

Ordering Ref : MV 794LP10K-6K-1/4R-P
Corresponding Ordering Ref : MV 7946502-D-L

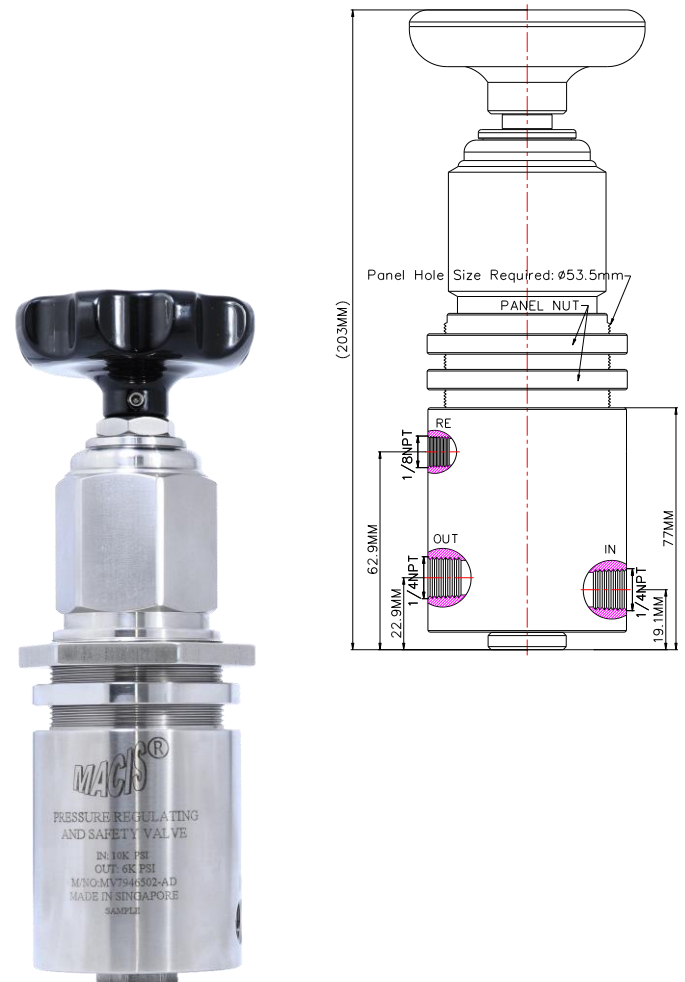

Ordering Ref : MV 794LF10K-6K-1/4R-P
Corresponding Ordering Ref : MV 7946502-AD-L

MACIS PTE LTD

Blk 3015A Ubi Road 1, #01-02 & #01-06 Kampong Ubi Industrial Estate, Singapore 408705
Email : sales@macis.com.sg Tel : 65-6749 6011 / 65-6749 7882 Fax : 65-6749 1398

Specification

Port Connection Size	Input: 1/4" - 18NPT F Output: 1/4" - 18NPT F Return: 1/8"-27NPT F
Net Weight	2.75 kg
Working Media	Air
Temperature Range	- 30°C to 120°C <i>Other Temperature Ranges available. Consult Factory</i>
Material(Valve Body)	316L
Working Pressure	Max Inlet Pressure: 10,000psi (689.4bar) Output Pressure Range: Services up to 6,000psi (413.7bar), Optimum 350~6,000 PSI (24.2-413.7 bar)
Adjusting Wheel Material	Polyamide <i>Other Material available, Consult Factory</i>
Orifice Size	Ø2.4mm($\frac{3}{32}$ ")
Flow Rate	Cv = 0.12
Seal Material	Viton (FKM) <i>Other Material are available, Consult Factory</i>

Distinctions

<u>Ordering Ref No</u>	<u>Mounting Hole</u>	<u>Lock Nut</u>	<u>Panel Hole</u>	<u>Finger /Palm Wheel</u>
MV 794LP10K-6K-1/4R-S:	Ø71.5mm ($2\frac{13}{16}$ ")	Without	Without	} Palm Wheel
MV 794LP10K-6K-1/4R-LS:	Ø71.5mm ($2\frac{13}{16}$ ")	With	Without	
MV 794LP10-6K-1/4R-P:	Without	Without	Ø53.5mm($2\frac{7}{64}$ ")	} Finger Wheel
MV 794LF10K-6K-1/4R-P:	Without	Without	Ø53.5mm($2\frac{7}{64}$ ")	

** Measurement stated are with tolerance of +/-10%. Optional Parts/Material are available upon request.